

High Pressure, Stainless Steel Rotary Unions

# HPS Series

FLOW PASSAGE OPTIONS

1

3

4

6

8

12

16

## Contents

- 3** What is a Rotary Union?
- 4** Overview
- 5** How To Order
- 6** Specifications & Operating Information
- 7** Performance Data
- 8** HPS 1 Passage Dimensions
- 9** HPS 3 Passage Dimensions
- 10** HPS 4 Passage Dimensions
- 11** HPS 6 Passage Dimensions
- 12** HPS 8 Passage Dimensions
- 13** HPS 12 Passage Dimensions
- 14** HPS 16 Passage Dimensions
- 15** Shaft Mounted Customer Interface
- 16** Information Plate Location
- 17** Installation & Mounting
- 17** Warranty

## About DSTI

Dynamic Sealing Technologies, Inc. (DSTI) serves a wide range of global industries as a leader in engineered fluid sealing and transfer solutions for rotating applications.

DSTI core business segments are fluid rotary unions, electrical slip rings, and value-added products and services—providing customers with a single-source solution from design and manufacturing through to testing and qualification—all under one roof. Located in North America and Europe with a team of distribution partners and technical support specialists worldwide.

Learn more at [www.dsti.com](http://www.dsti.com)



### **DID YOU KNOW?**

DSTI Exports Products to Over 60 Countries.

## What is a Rotary Union?

A rotary union (or swivel joint) is a mechanism used to transfer fluid (under pressure or vacuum) from a stationary inlet to a rotating outlet, preserving and isolating the fluid connection.

Rotary unions are engineered to endure a wide range of temperatures and pressures for a variety of conditions and environments. In addition, rotary unions may integrate multiple passages and handle different types of fluid simultaneously.

See examples at [www.dsti.com/industries](http://www.dsti.com/industries)

### HOW DO I CHOOSE THE BEST ROTARY UNION FOR MY APPLICATION?

Tell us about your requirements so we can make a recommendation:

- 1) Type of media(s) / fluid(s) to be transferred
- 2) Number of independent flow channels (passages)
- 3) Operating pressure
- 4) Operating temperature
- 5) Operating speed
- 6) Shaft & housing connection type
- 7) Flow channel (passage) size
- 8) Torque & load requirements
- 9) Duty cycle\*

\*Does the temperature, speed or pressure fluctuate or change during operation? If so, please provide the detailed ranges for each parameter and time durations of each condition.

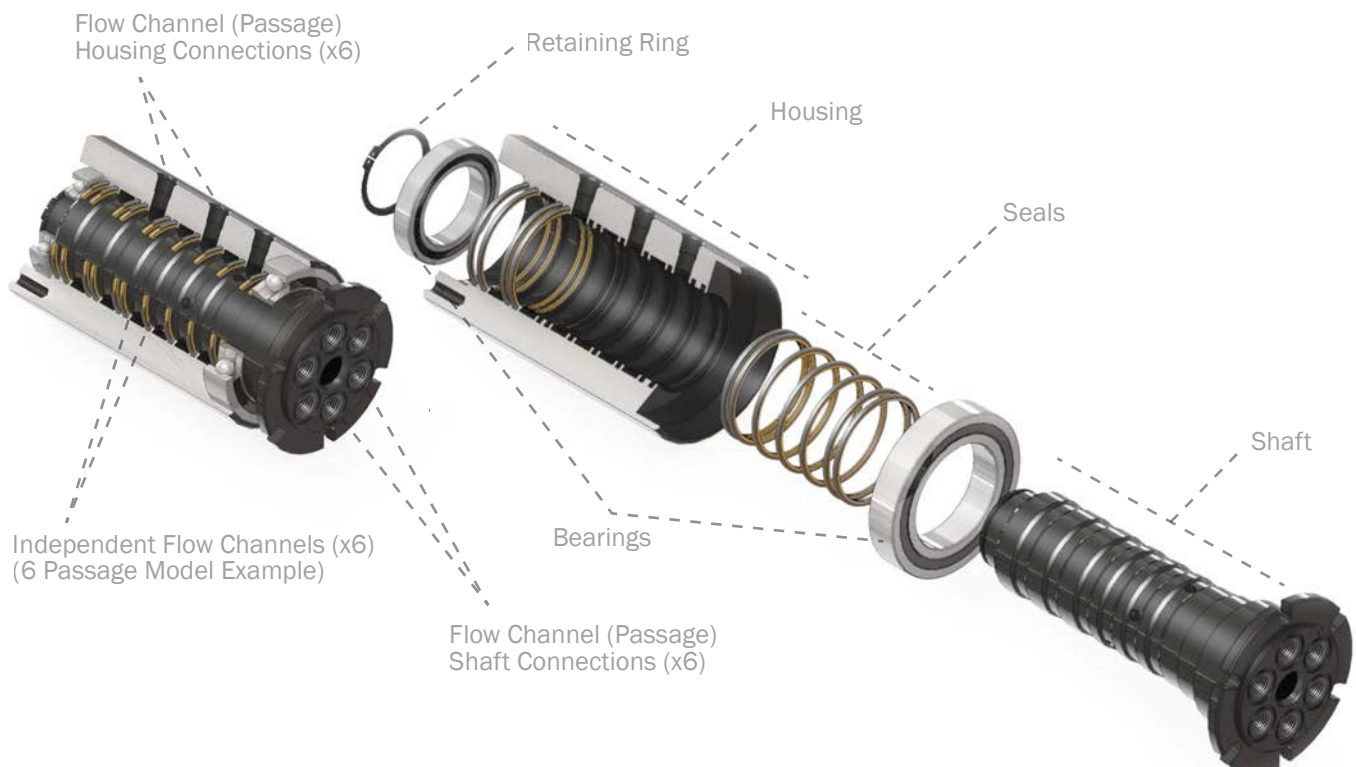

## Overview

- + High Pressure Requirements Up To 20,000 PSI
- + Complete Stainless Steel Construction
- + Suitable For Use In Marine & Offshore Environments
- + Medium Pressure Housing Connections
- + O-ring Flange Mount Shaft Connections
- + Custom Modifications Available

Available in 1, 3, 4, 6, 8, 12 and 16 passage models, DSTI HPS Series rotary unions are capable of handling pressures up to 20,000 PSI [1,375 BAR].

All HPS Series models feature a corrosion-resistant, all-stainless steel construction for harsh marine and offshore environmental conditions and corrosive media transfer.



Medium pressure housing connections and O-ring gland shaft connections come standard for HPS Series models, suitable for common applications including umbilical hose reel systems and other high pressure equipment.

If needed, DSTI can make modifications to meet each application's specific requirements including changes to the HPS Series mounting configuration, connections, sealing system, and housing or shaft dimensions.



### PRODUCT DOWNLOADS

For Catalogs, Brochures, Models and Drawings visit [www.dsti.com/downloads](http://www.dsti.com/downloads)

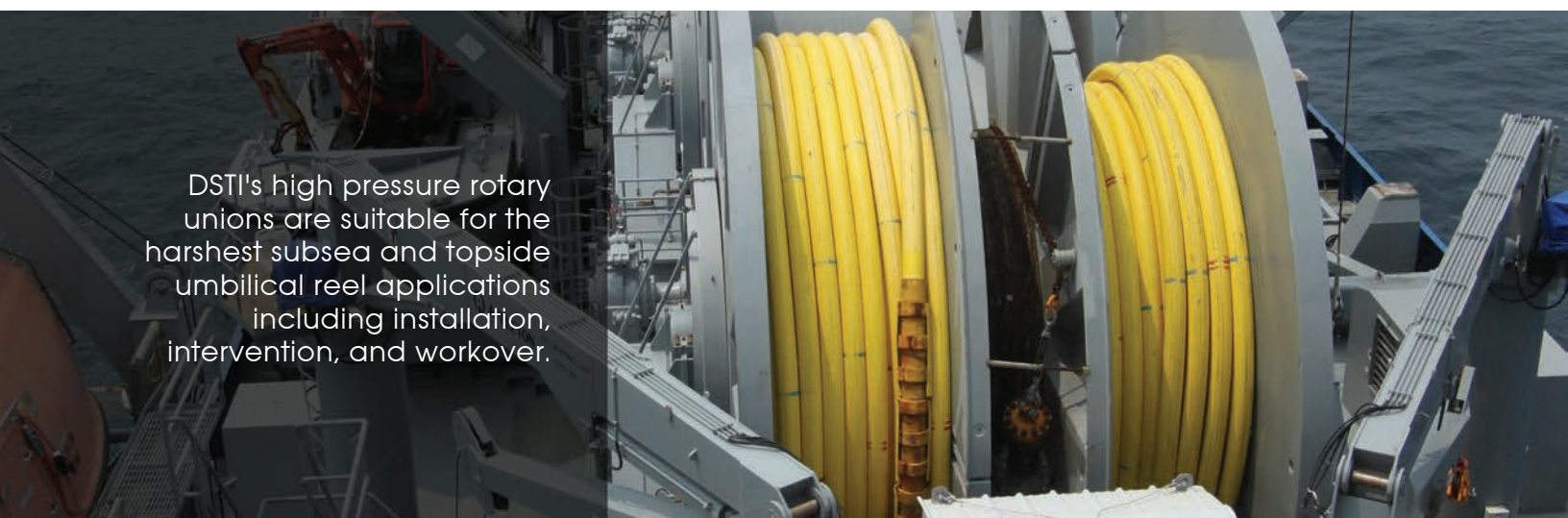

DSTI's high pressure rotary unions are suitable for the harshest subsea and topside umbilical reel applications including installation, intervention, and workover.

## How to Order: Create your Part Number

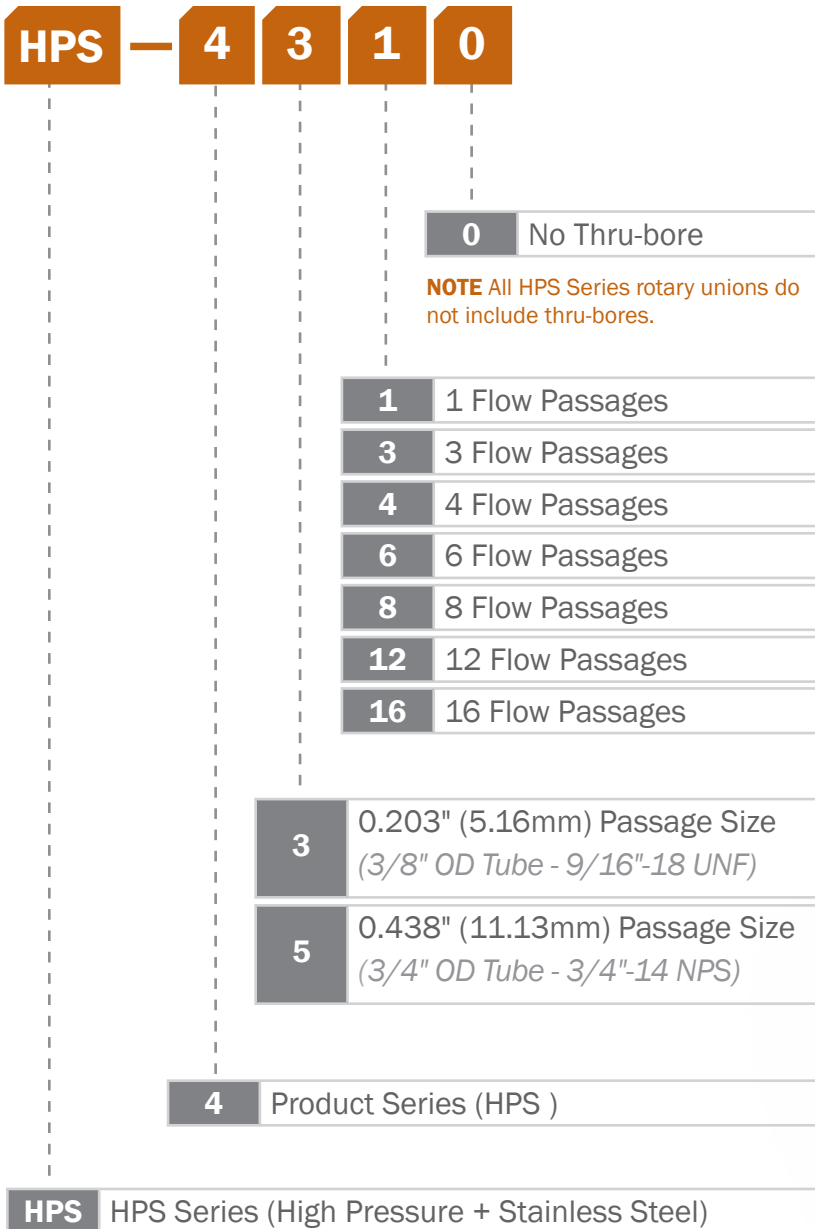

### PART NUMBER EXAMPLES

#### HPS-4310

- HPS 1-Passage with a 3/8" tube - 9/16"-18 UNF Medium Pressure Connection

#### HPS-43120

- HPS 12-Passage with a 3/8" tube - 9/16"-18 UNF Medium Pressure Connection

#### HPS-4510

- HPS 1-Passage with a 3/4" tube - 3/4"-14 NPS Medium Pressure Connection



**CONNECTION TYPE** 3/8" tube - 9/16"-18 UNF Medium Pressure Connections

(3/4" tube - 3/4"-14 NPS Medium Pressure Connection on HPS-4510 Model only)

O-ring flange mount shaft connections standard. (Optional threaded face connections available)



## Specifications & Operating Information

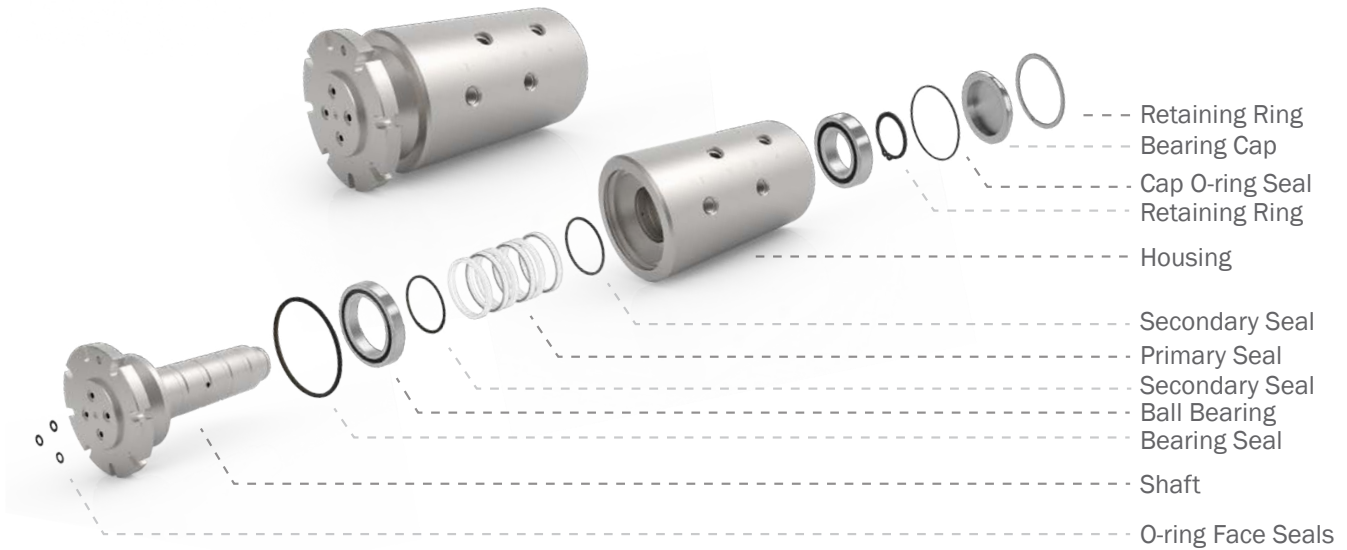

Flow Passage Options	1	3	4	6	8	12	16
Media Types	Oil/Hydraulic, Water/Glycol						
Passage Sizes	0.203" (5.15mm), 0.438" (11.13mm)						
Connection Types	Medium pressure housing connections & O-ring flange mount shaft connections						
Max. Operating Pressure	20,000 PSI (1,375 BAR) <sup>1</sup>						
Max. Vacuum	N/A - Not for use with vacuum						
Max. Rotational Speed	50 RPM <sup>1</sup>						
Operating Temperature	0° F to 220° F (-18° C to 105° C) <sup>2</sup>						
Body Material Type	Stainless Steel						
Platings and Coatings	Stainless Steel						
Slip Ring Options	Custom options available. Please consult with DSTI						
Mounting Options	The HPS series unions have o-ring glands on the face of the shaft for flush mounting. There are also tapped holes on the end of the housing & bolt slots on the shaft flange for mounting the assembly.						

<sup>1</sup> Values are dependent on a combination of all application parameters. Please consult with DSTI.

<sup>2</sup> High temperature applications may require alternative seal materials. Please consult with DSTI.

## Performance Data: Pressure vs. Speed (Continuous)

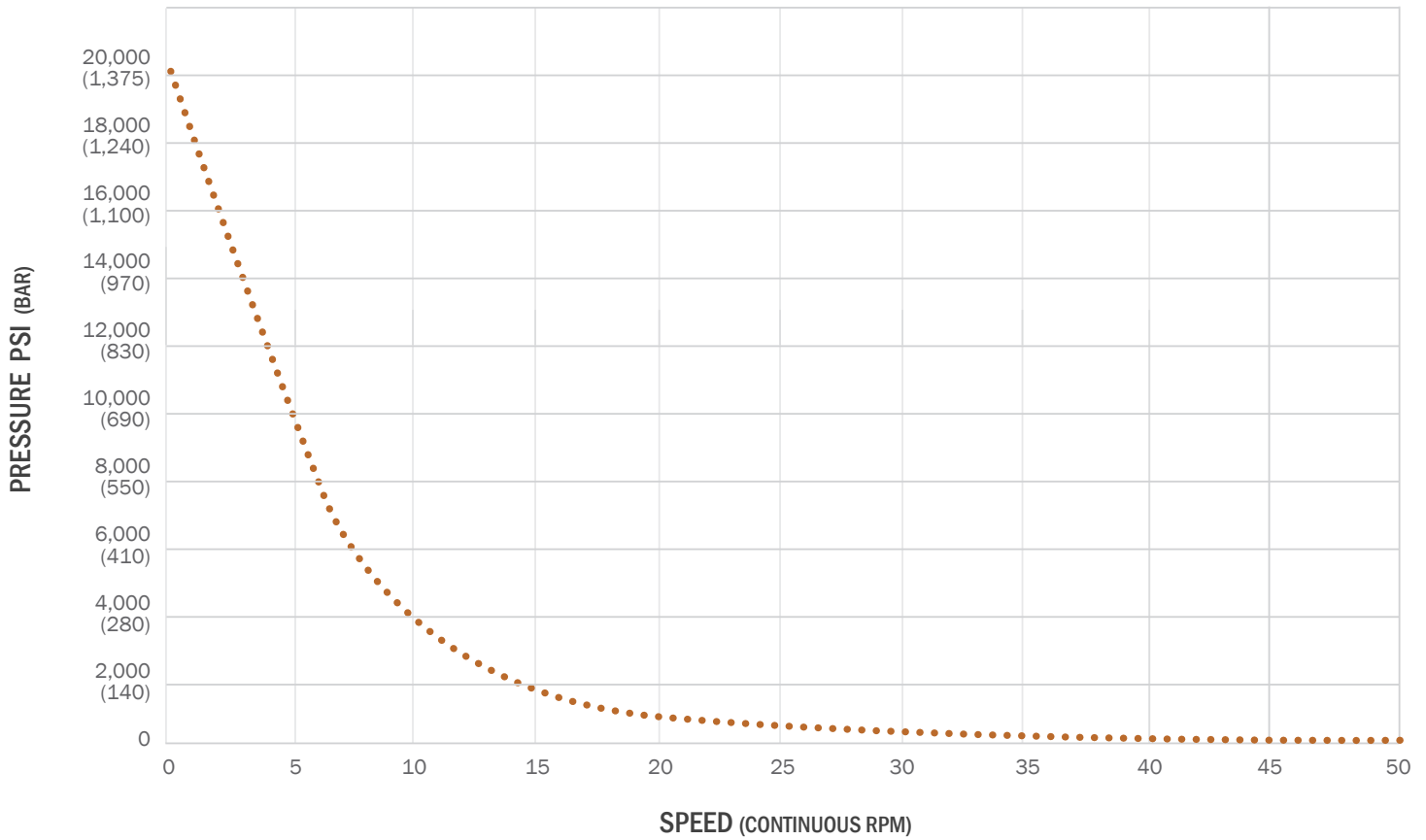

\* This data is to be used as a general guideline. Data based on using hydraulic fluid with the product rotating continuously. Please consult DSTI about your specific application.

## 1 Flow Passage: Dimensions

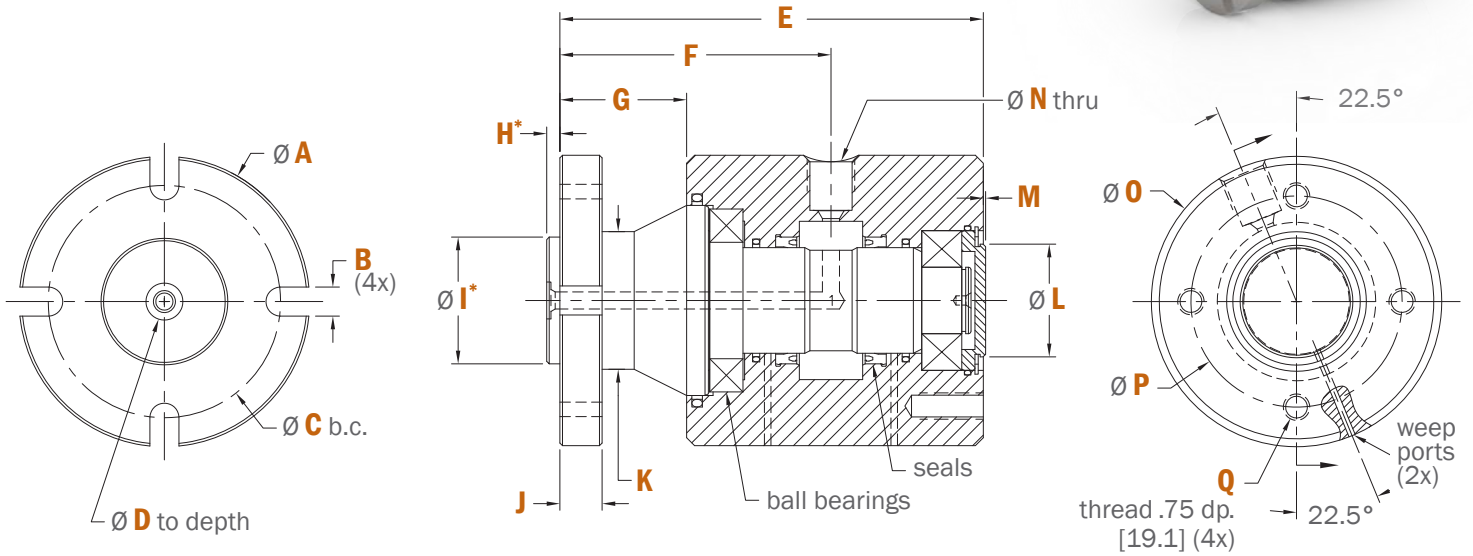

	HPS-4310	HPS-4510
<b>A</b>	3.438" [87.33mm]	3.438" [87.33mm]
<b>B</b>	0.344" [8.74mm]	0.344" [8.74mm]
<b>C</b>	2.750" [69.85mm]	2.750" [69.85mm]
<b>D</b>	0.203" [5.16mm]	0.438" [11.13mm]
<b>E</b>	5.01" [127.3mm]	5.01" [127.3mm]
<b>F</b>	3.21" [81.5mm]	3.21" [81.5mm]
<b>G</b>	1.50" [38.10mm]	1.50" [38.1mm]
<b>H</b>	0.156" [3.96mm]	0.156" [3.96mm]
<b>I</b>	1.500" [38.10mm]	1.500" [38.10mm]
<b>J</b>	0.500" [12.70mm]	0.500" [12.70mm]
<b>K</b>	1.630" [41.40mm]	1.630" [41.40mm]
<b>L</b>	1.33" [33.9mm]	1.33" [33.9mm]
<b>M</b>	0.03" [0.7mm]	0.03" [0.7mm]
<b>N</b>	0.203" [5.16mm] 3/8" OD tube - 9/16" - 18 UNF	0.438" [11.13mm] 3/4" OD tube - 3/4" - 14 NPS
<b>O</b>	3.437" [87.30mm]	4.437" [112.70mm]
<b>P</b>	2.500" [63.50mm]	3.500" [88.90mm]
<b>Q</b>	5/16" - 18 UNC	5/16"-18 UNC

\* Critical tolerances listed in the Customer Interface Section on page 15.  
Reference tolerances listed on the PDF Part Drawing.



## 3 Flow Passage: Dimensions

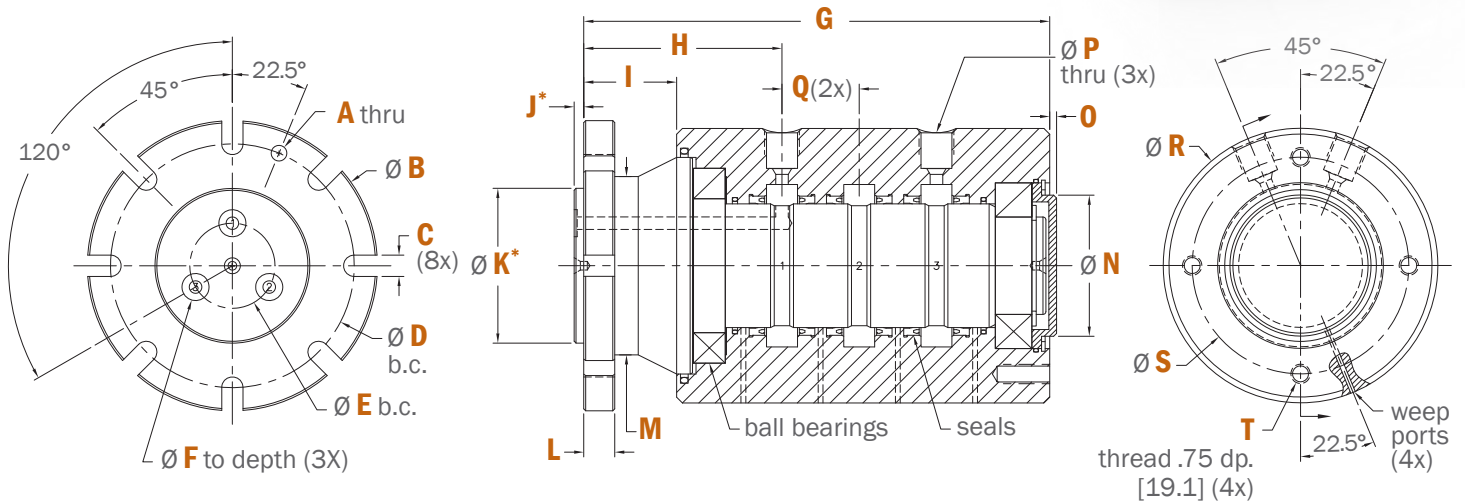

HPS-4330			
<b>A</b>	0.252" [6.401mm]	<b>K</b>	2.500" [63.50mm]
<b>B</b>	4.688" [119.08mm]	<b>L</b>	0.500" [12.70mm]
<b>C</b>	0.344" [8.74mm]	<b>M</b>	2.88" [73.2mm]
<b>D</b>	3.938" [100.01mm]	<b>N</b>	2.28" [57.9mm]
<b>E</b>	1.375" [34.93mm]	<b>O</b>	0.11" [2.8mm]
<b>F</b>	0.203" [5.16mm]	<b>P</b>	0.203" [5.16mm] 3/8" OD tube - 9/16" - 18 UNF
<b>G</b>	7.53" [191.2mm]	<b>Q</b>	1.248" [31.70mm]
<b>H</b>	3.20" [81.4mm]	<b>R</b>	4.437" [112.70mm]
<b>I</b>	1.50" [38.1mm]	<b>S</b>	3.500" [88.90mm]
<b>J</b>	0.156" [3.96mm]	<b>T</b>	5/16"-18 UNC

\* Critical tolerances listed in the Customer Interface Section on page 15.  
Reference tolerances listed on the PDF Part Drawing.

## 4 Flow Passage: Dimensions

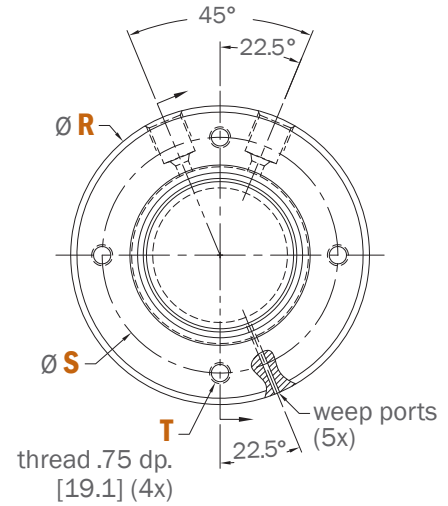
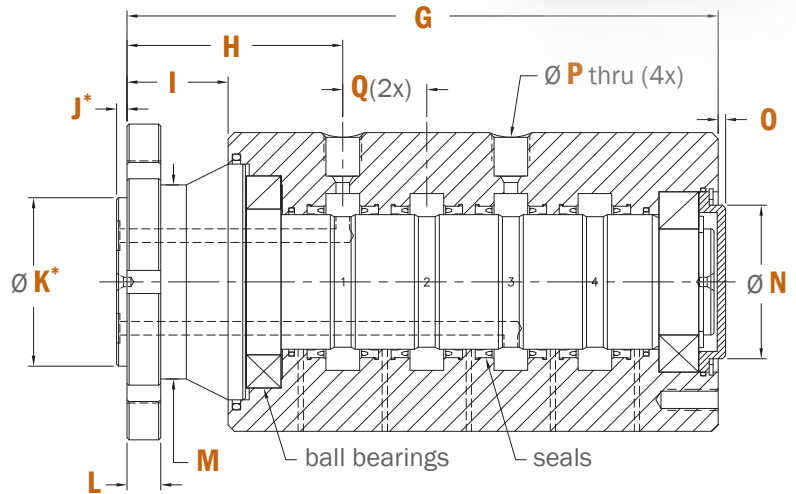
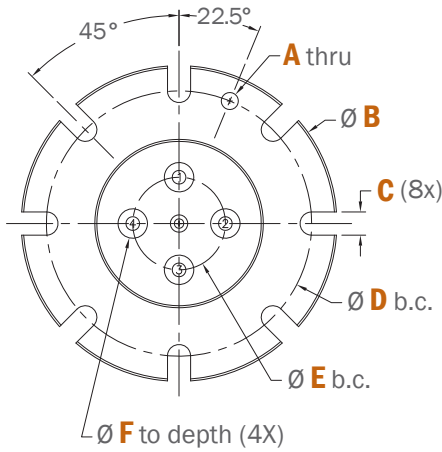

HPS-4340			
<b>A</b>	0.252" [6.401mm]	<b>K</b>	2.500" [63.500mm]
<b>B</b>	4.688" [119.08mm]	<b>L</b>	0.500" [12.70mm]
<b>C</b>	0.344" [8.74mm]	<b>M</b>	2.88" [73.2mm]
<b>D</b>	3.938" [100.01mm]	<b>N</b>	2.28" [57.9mm]
<b>E</b>	1.375" [34.93mm]	<b>O</b>	0.11 [2.8mm]
<b>F</b>	0.203" [5.16mm]	<b>P</b>	0.203" [5.16mm] 3/8" OD tube - 9/16" - 18 UNF
<b>G</b>	8.78" [222.9mm]	<b>Q</b>	1.248" [81.4mm]
<b>H</b>	3.20" [81.4mm]	<b>R</b>	4.437" [112.70mm]
<b>I</b>	1.50" [38.1mm]	<b>S</b>	3.500" [88.90mm]
<b>J</b>	0.156" [3.962mm]	<b>T</b>	5/16"-18 UNC

\* Critical tolerances listed in the Customer Interface Section on page 15.  
Reference tolerances listed on the PDF Part Drawing.

## 6 Flow Passage: Dimensions

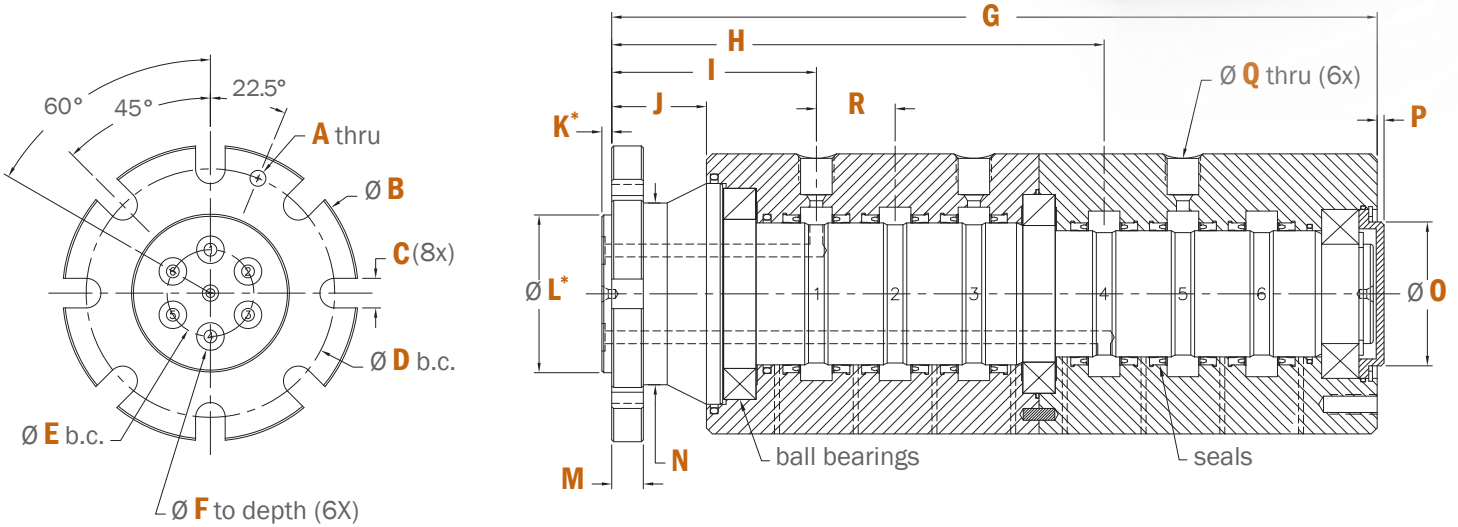

HPS-4360			
<b>A</b>	0.252" [6.401mm]	<b>L</b>	2.500" [63.50mm]
<b>B</b>	4.688" [119.08mm]	<b>M</b>	0.500" [12.70mm]
<b>C</b>	0.469" [11.91mm]	<b>N</b>	2.88" [73.2mm]
<b>D</b>	3.938" [100.01mm]	<b>O</b>	2.28" [57.9mm]
<b>E</b>	1.375" [34.93mm]	<b>P</b>	0.11" [2.8mm]
<b>F</b>	0.203" [5.16mm]	<b>Q</b>	0.203" [5.16mm] 3/8" OD tube - 9/16" - 18 UNF
<b>G</b>	12.13" [308.1mm]	<b>R</b>	1.248" [31.70mm]
<b>H</b>	7.80" [198.2mm]	<b>S</b>	4.437" [112.70mm]
<b>I</b>	3.24" [82.4mm]	<b>T</b>	3.500" [88.90mm]
<b>J</b>	1.50" [38.1mm]	<b>U</b>	5/16"-18 UNC
<b>K</b>	0.156" [3.96mm]		

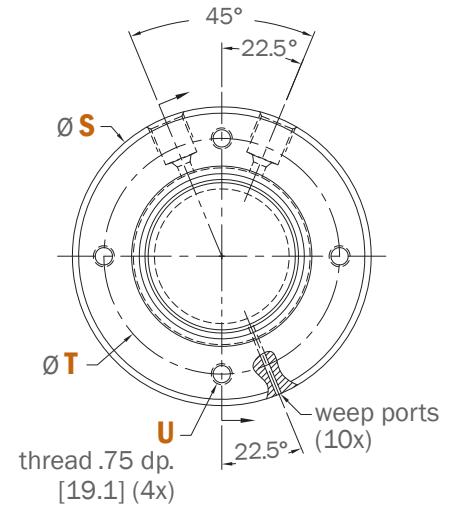

\* Critical tolerances listed in the Customer Interface Section on page 15.  
Reference tolerances listed on the PDF Part Drawing.

## 8 Flow Passage: Dimensions

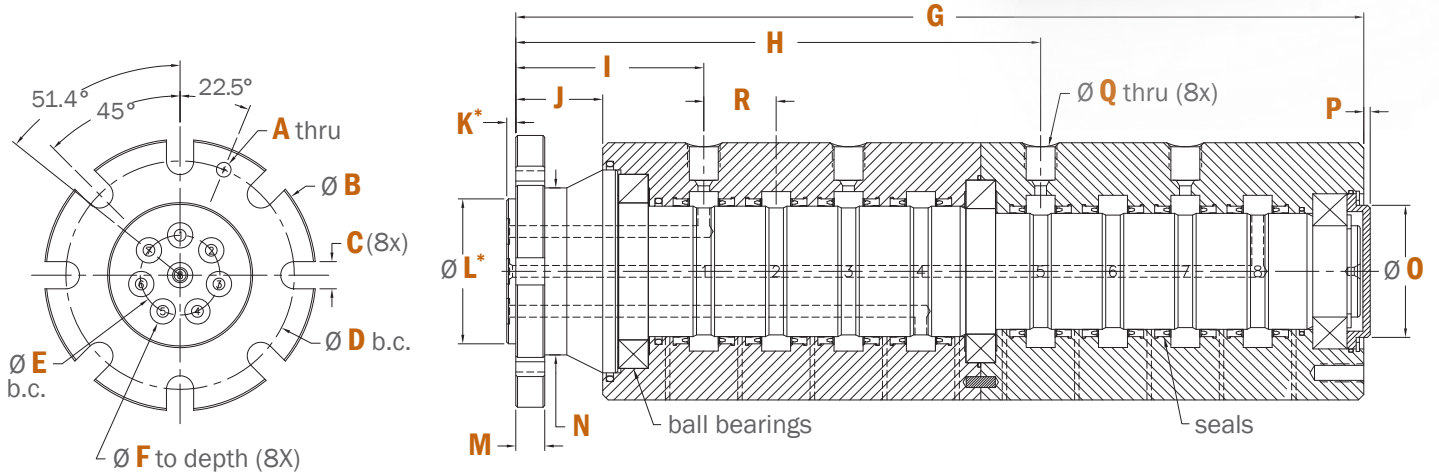

HPS-4380			
<b>A</b>	0.252" [6.401mm]	<b>L</b>	2.500" [63.50mm]
<b>B</b>	4.688" [119.08mm]	<b>M</b>	0.500" [12.70mm]
<b>C</b>	0.469" [11.91mm]	<b>N</b>	2.88" [73.2mm]
<b>D</b>	3.938" [100.01mm]	<b>O</b>	2.28" [57.9mm]
<b>E</b>	1.375" [34.93mm]	<b>P</b>	0.11" [2.8mm]
<b>F</b>	0.203" [5.16mm]	<b>Q</b>	0.203" [5.16mm] 3/8" OD tube - 9/16" - 18 UNF
<b>G</b>	14.63" [371.5mm]	<b>R</b>	1.248" [31.70mm]
<b>H</b>	9.05" [229.9mm]	<b>S</b>	4.437" [112.70mm]
<b>I</b>	3.24" [82.4mm]	<b>T</b>	3.500" [88.90mm]
<b>J</b>	1.50" [38.1mm]	<b>U</b>	5/16"-18 UNC
<b>K</b>	0.156" [3.96mm]		

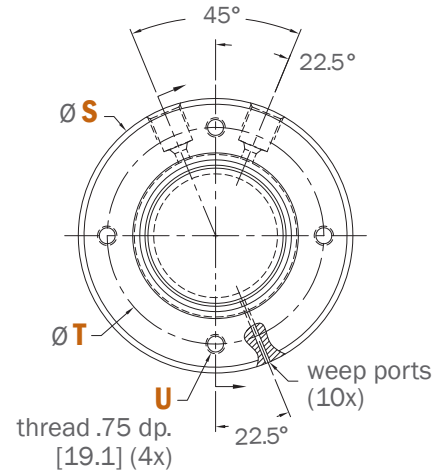

\* Critical tolerances listed in the Customer Interface Section on page 15.  
Reference tolerances listed on the PDF Part Drawing.

## 12 Flow Passage: Dimensions

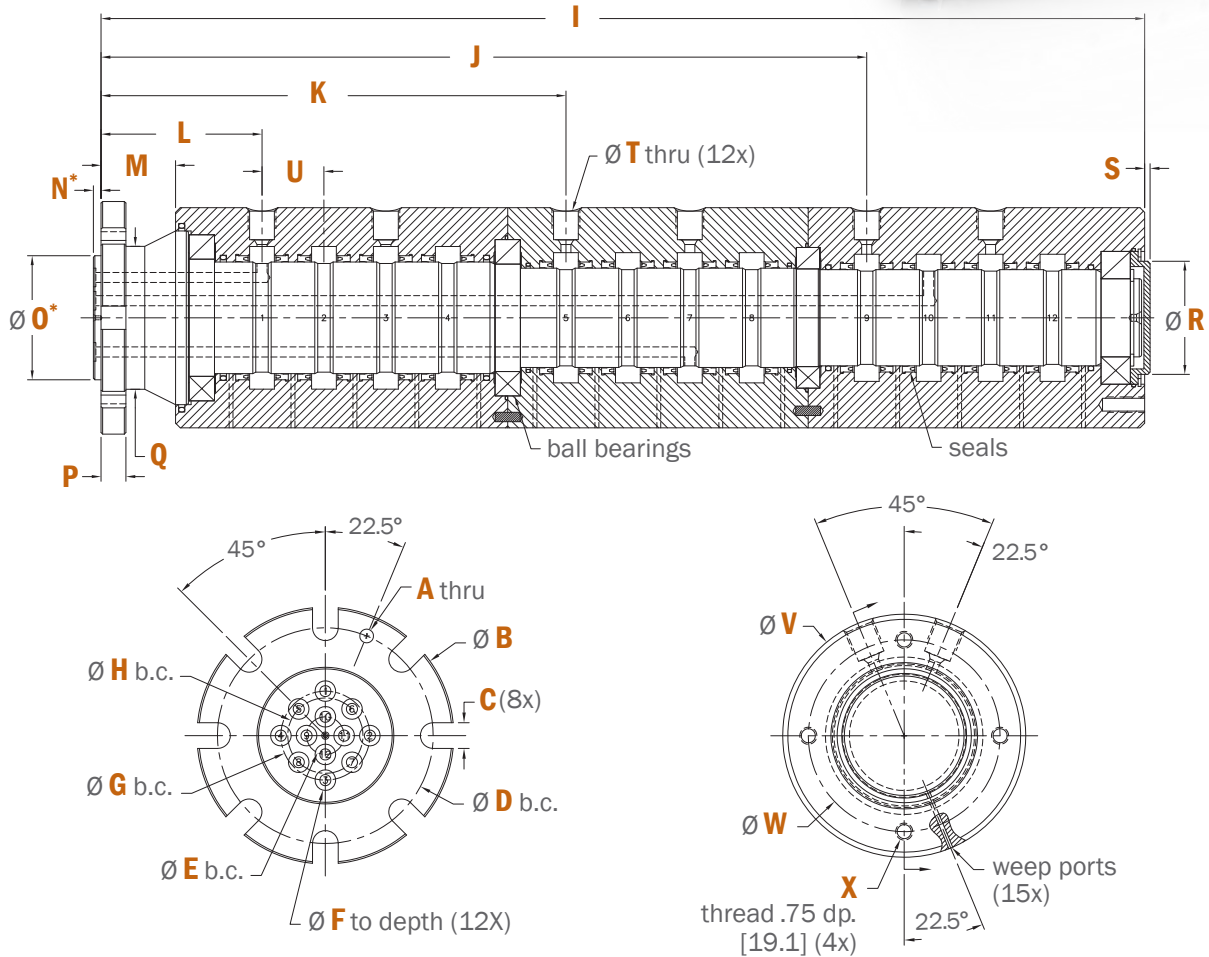

HPS-43120			
<b>A</b>	0.252" [6.401mm]	<b>M</b>	1.50" [38.1mm]
<b>B</b>	4.688" [119.08mm]	<b>N</b>	0.156" [3.96mm]
<b>C</b>	0.469" [11.91mm]	<b>O</b>	2.500" [63.50mm]
<b>D</b>	3.938" [100.03mm]	<b>P</b>	0.500" [12.70mm]
<b>E</b>	0.678" [17.45mm]	<b>Q</b>	2.88" [73.2mm]
<b>F</b>	0.203" [5.16mm]	<b>R</b>	2.28" [57.9mm]
<b>G</b>	1.625" [41.28mm]	<b>S</b>	0.11" [2.8mm]
<b>H</b>	1.375" [34.93mm]	<b>T</b>	0.203" [5.16mm] 3/8" OD tube - 9/16" - 18 UNF
<b>I</b>	21.03" [534.1mm]	<b>U</b>	1.248" [31.70]
<b>J</b>	15.43" [391.9mm]	<b>V</b>	4.437" [112.70mm]
<b>K</b>	9.37" [237.9mm]	<b>W</b>	3.500" [88.90mm]
<b>L</b>	3.24" [82.4mm]	<b>X</b>	5/16"-18 UNC

\* Critical tolerances listed in the Customer Interface Section on page 15.  
Reference tolerances listed on the PDF Part Drawing.

## 16 Flow Passage: Dimensions

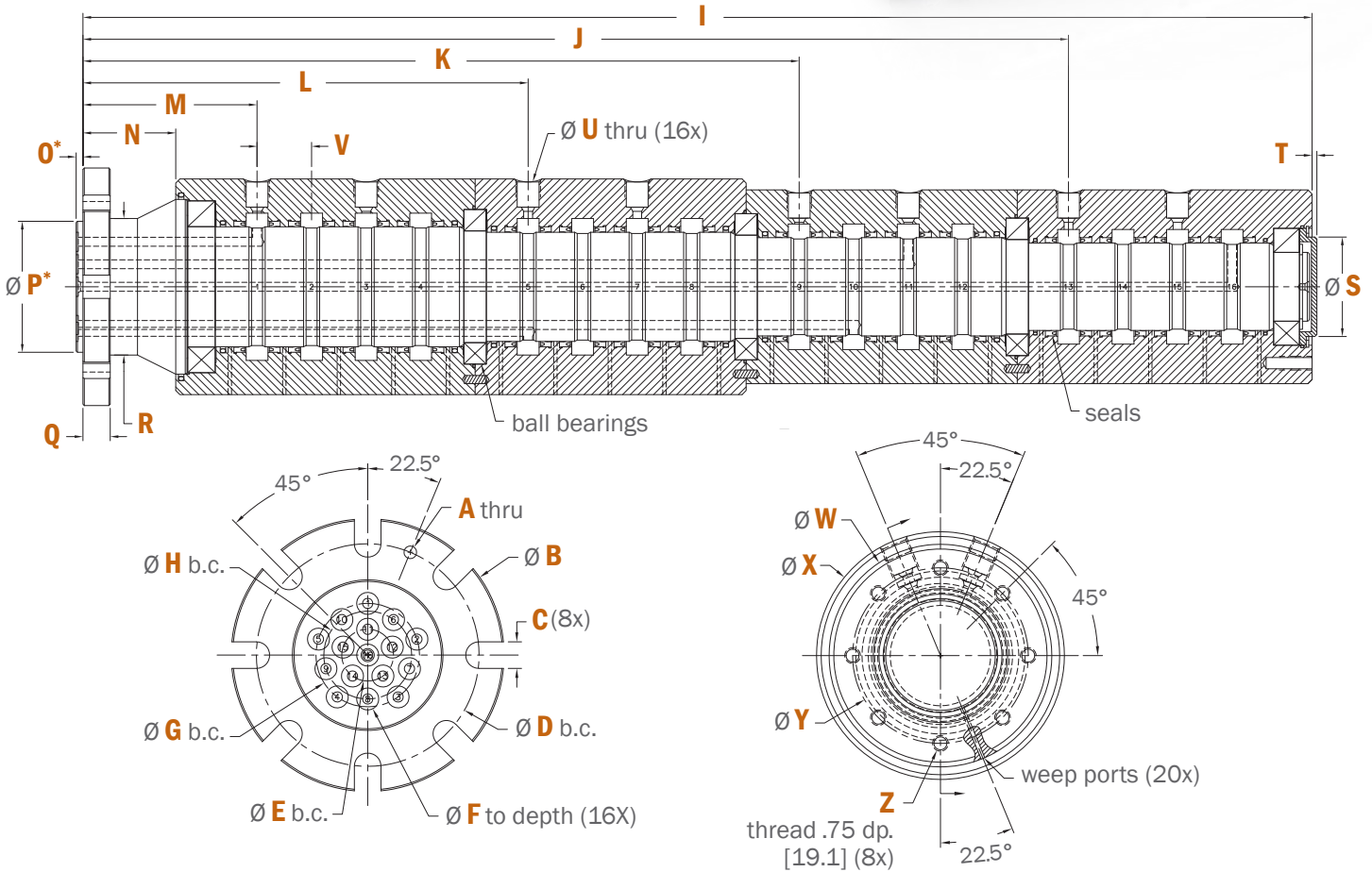
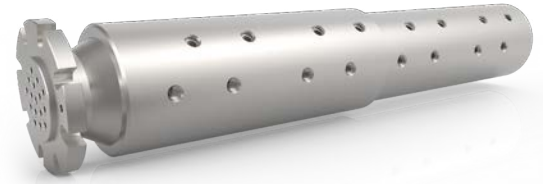

HPS-43160			
<b>A</b>	0.252" [6.401mm]	<b>N</b>	2.13" [54.0mm]
<b>B</b>	5.438" [138.13mm]	<b>O</b>	0.156" [3.96mm]
<b>C</b>	0.531" [13.49mm]	<b>P</b>	3.000" [76.20mm]
<b>D</b>	4.438" [112.71mm]	<b>Q</b>	0.625" [15.88mm]
<b>E</b>	1.031" [26.19mm]	<b>R</b>	3.13" [79.4mm]
<b>F</b>	0.203" [5.16mm]	<b>S</b>	2.28" [57.9mm]
<b>G</b>	2.062" [52.37mm]	<b>T</b>	0.11" [2.8mm]
<b>H</b>	1.750" [44.45mm]	<b>U</b>	0.203" [5.16mm] 3/8" OD tube - 9/16" - 18 UNF
<b>I</b>	28.13" [714.6mm]	<b>V</b>	1.248" [31.70mm]
<b>J</b>	22.56" [573.0mm]	<b>W</b>	4.437" [112.70mm]
<b>K</b>	16.39" [416.4mm]	<b>X</b>	4.938" [125.43mm]
<b>L</b>	10.19" [258.8mm]	<b>Y</b>	3.500" [88.90mm]
<b>M</b>	3.99" [101.2mm]	<b>Z</b>	5/16"-18 UNC

\* Critical tolerances listed in the Customer Interface Section on page 15.  
Reference tolerances listed on the PDF Part Drawing.



## Shaft Mounted Customer Interface

CUSTOMER INTERFACE EXAMPLE



HPS SERIES ROTARY UNION

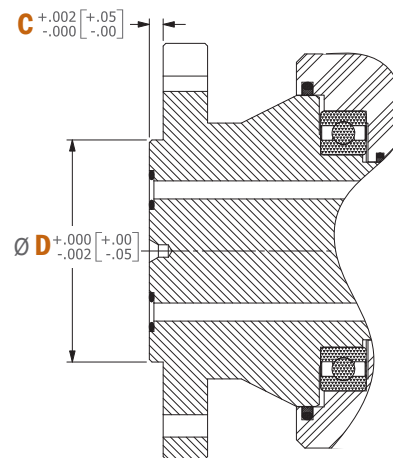
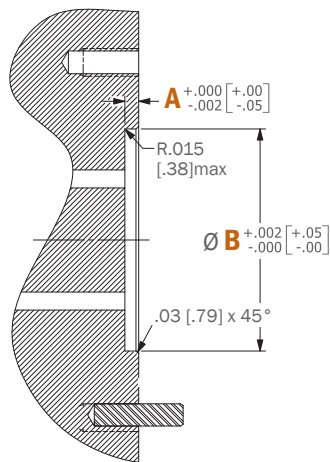

PART #	A	B	C	D	E (min)
<b>HPS-4310</b>	0.156" [3.96mm]	1.501" [38.13mm]	0.156" [3.96mm]	1.500" [38.10mm]	0.438" [11.13mm]
<b>HPS-4510</b>	0.156" [3.96mm]	1.501" [38.13mm]	0.156" [3.96mm]	1.500" [38.10mm]	0.438" [11.13mm]
<b>HPS-4330</b>	0.156" [3.96mm]	2.501" [63.53mm]	0.156" [3.96mm]	2.500" [63.50mm]	0.438" [11.13mm]
<b>HPS-4340</b>	0.156" [3.96mm]	2.501" [63.53mm]	0.156" [3.96mm]	2.500" [63.50mm]	0.438" [11.13mm]
<b>HPS-4360</b>	0.156" [3.96mm]	2.501" [63.53mm]	0.156" [3.96mm]	2.500" [63.50mm]	0.438" [11.13mm]
<b>HPS-4380</b>	0.156" [3.96mm]	2.501" [63.53mm]	0.156" [3.96mm]	2.500" [63.50mm]	0.438" [11.13mm]
<b>HPS-43120</b>	0.156" [3.96mm]	2.501" [63.53mm]	0.156" [3.96mm]	2.500" [63.50mm]	0.375" [9.53mm]
<b>HPS-43160</b>	0.156" [3.96mm]	3.001" [76.23mm]	0.156" [3.96mm]	3.000" [76.20mm]	0.438" [11.13mm]

## Information Plate Location



## Installation & Mounting

### PREPARATION:

Remove the rotary union from the shipping container. Inspect the entire assembly, including all passage connections to make sure that they are clean and no visual damage occurred during transport.

### RECOMMENDED INSTALLATION PRACTICE:

DSTI does not recommend mounting the rotary union with both the shaft & housing components solidly bolted into place. One of the two components should be mounted in a manner that allows for some movement in the event of misalignment or run-out during rotation. Using only the supply lines or hoses to fix the stationary component in place is also not recommended. An anti-rotation arm that attaches to the stationary part of the rotary union assembly and rests against part of the equipment framework is recommended (see figure 1).

### SHAFT MOUNTING

Make sure the rotary union shaft face & equipment mounting surface is clean and free from dents or chips to insure proper installation. Equipment pilot bore needs to be concentric to the center line of the rotary union shaft to assure proper function. Install face mount O-rings into groove or counter bore in rotating union shaft face. General assembly grease can be used as needed to hold O-rings into place during assembly. Align rotary union shaft with equipment pilot bore and flow passages, then insert into place. Bolt assembly into place using the mounting flange on rotary union face.

THESE INSTRUCTIONS ARE INTENDED TO BE USED AS A GENERAL GUIDE, PLEASE CONSULT DSTI TO DISCUSS ANY SPECIFIC QUESTIONS RELATED TO YOUR INSTALLATION.

### INITIAL START-UP:

After rotary union is installed, a dry run is recommended to assure proper mounting of the rotating union assembly. Begin rotation of the equipment, and verify that while rotating at the maximum operating speed there is no visible movement of the rotary union assembly due to misalignment.



- FIGURE 1
- ① HPS HOUSING
  - ② HPS SHAFT
  - ③ ANTI-ROTATE DEVICE EXAMPLE

## Warranty

DSTI Warrants, for a period of 2 years from the date of original delivery, its products to be free from defects in material and workmanship. DSTI's obligation under this warranty is limited to repair or replacement at its factory of any part or parts of said products which shall be returned to DSTI with transportation charges prepaid and which DSTI's examination shall disclose to its satisfaction to have been defective. Under no circumstances shall DSTI be held liable for loss, damage, cost of repair or consequential damages of any kind in connection with the sale, use or repair of any product purchased from DSTI. Warranty is subject to change.

# Engineered Fluid Solutions

At DSTI, our product solutions are directly influenced by the industries we serve. If an existing product isn't a perfect fit for our customers' applications, we provide specialized design and manufacturing services to meet the needs of their specifications.

To see examples of our customized solutions, please visit: [www.dsti.com/industries](http://www.dsti.com/industries)



## PRODUCT DOWNLOADS

For Catalogs, Brochures, Models and Drawings visit:

[www.dsti.com/downloads](http://www.dsti.com/downloads)

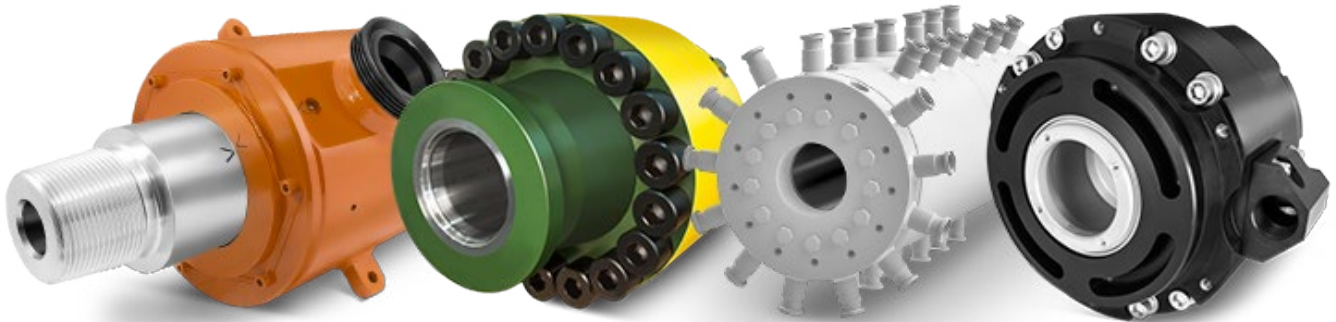

Dynamic Sealing Technologies, Inc

13829 Jay Street NW  
Andover, MN 55304  
USA

**main** 763.786.3785  
**toll free** 866.700.3784  
**web** [www.dsti.com](http://www.dsti.com)